

PROPELLER FAN



TRANSMONK
INDIA PVT. LTD.

The fan & HVAC Accessories Manufacturing

Transmonk believes in supplying 3 R's to the customers

Robust

With different levels of testing and intensive designing process we ensure that fans can perform their best in rugged application and highly stressed environment.

Reliable

With high quality motor (IP protection & Thermal class) and impeller, we ensure that the customer gets the most reliable product. The life of each fan is estimated approximately 40,000 hours when the fan is running continuously at rated voltage, rated load and maximum operating temperature.

Reasonable

Intelligent use of our compatible control system like automatic AC fan speed controller based on temperature (for 1Phase fans), make them more efficient and user friendly. This combination of fan and the controller makes the system more efficient as well as cost effective in terms of power consumption.

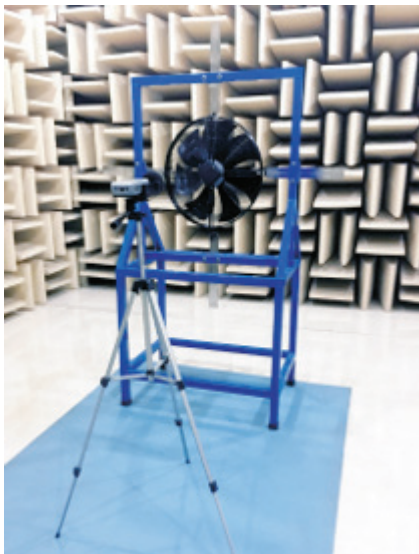

Acoustic testing chamber



Robotic Welding



Paint Shop

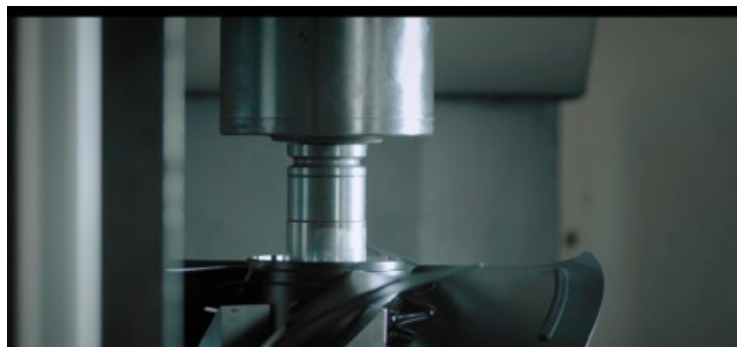

Fully Automatic CNC machine



Precise RPM calculation



200 mm: TPF-2E-200A-5F

Diameter	200 mm
Power Supply	1~230 V, 50 Hz
Airflow @ 0 Pascal	700 m ³ /hr
RPM	2650 min-1
Power Consumption	45 Watts
Current	0.2 Ampere
Capacitor	2 uF
Sound Pressure @ 1 Meter	54 dB (A)
Thermal Protection	F (155°C)
Protection Class	IP44
Net Weight	3 Kg

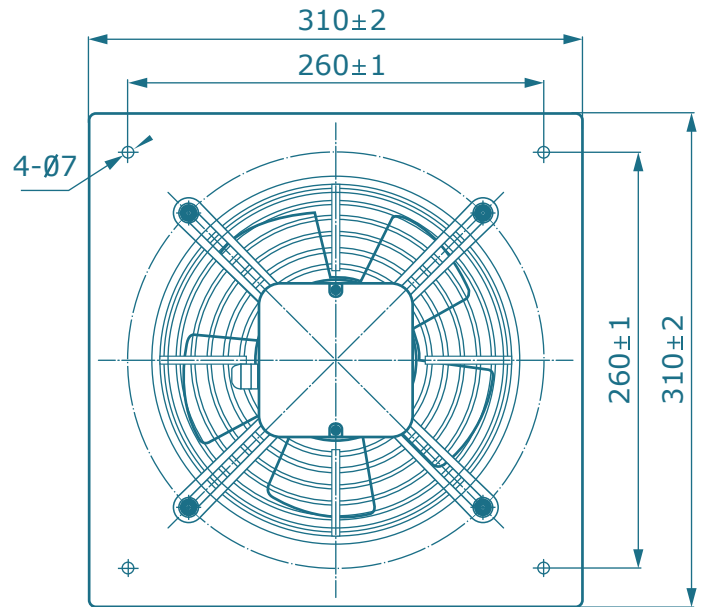

Airflow curves

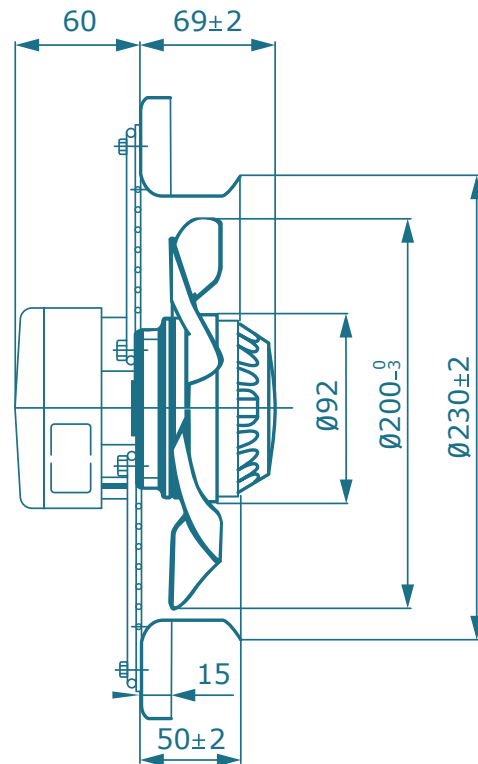
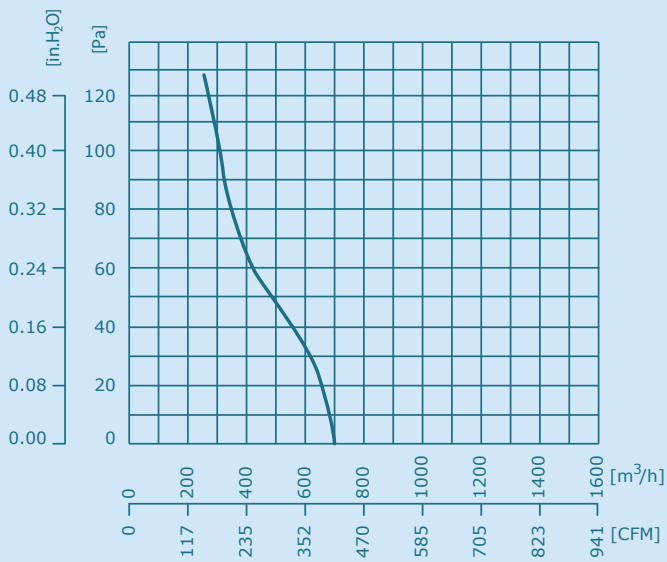

250 mm: TPF-4E-250A-5F

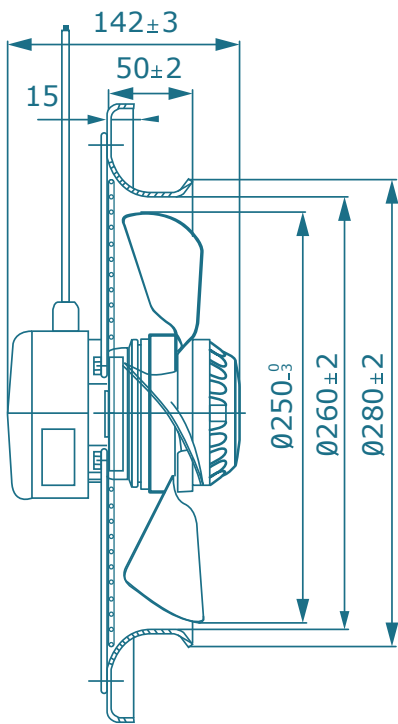
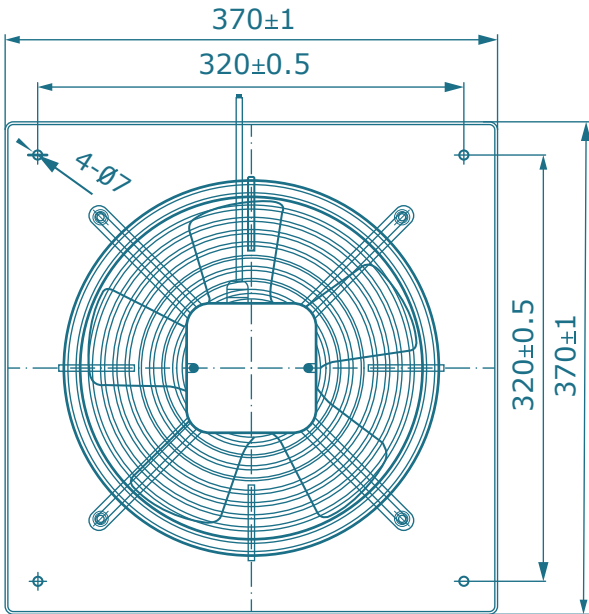

Diameter	250 mm
Power Supply	1~230 V, 50 Hz
Airflow @ 0 Pascal	1100 m ³ /hr
RPM	1400 min ⁻¹
Power Consumption	55 Watts
Current	0.25 Ampere
Capacitor	2 uF
Sound Pressure @ 1 Meter	49 dB (A)
Thermal Protection	F (155°C)
Protection Class	IP44
Net Weight	3.8 Kg

Airflow curves

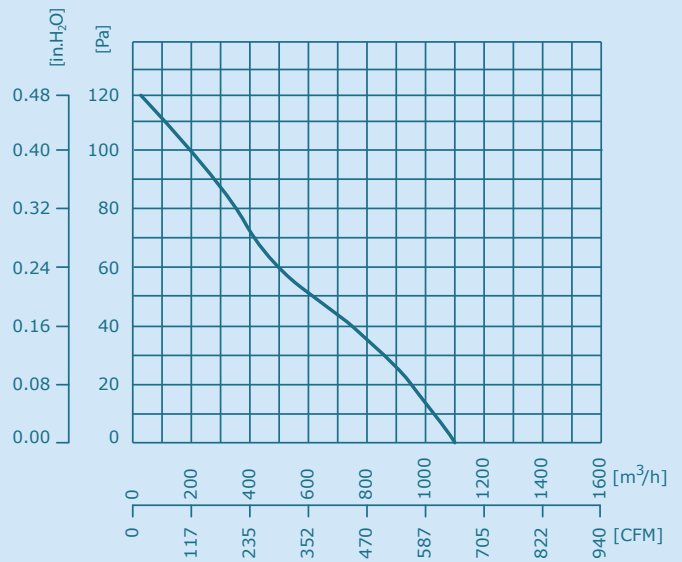

300 mm: TPF-4E-300A-5F

Diameter	300 mm
Power Supply	1~230 V, 50 Hz
Airflow @ 0 Pascal	1800 m ³ /hr
RPM	1350 min-1
Power Consumption	90 Watts
Current	0.42 Ampere
Capacitor	3 uF
Sound Pressure @ 1 Meter	52 dB (A)
Thermal Protection	F (155 °C)
Protection Class	IP44
Net Weight	5.2 Kg

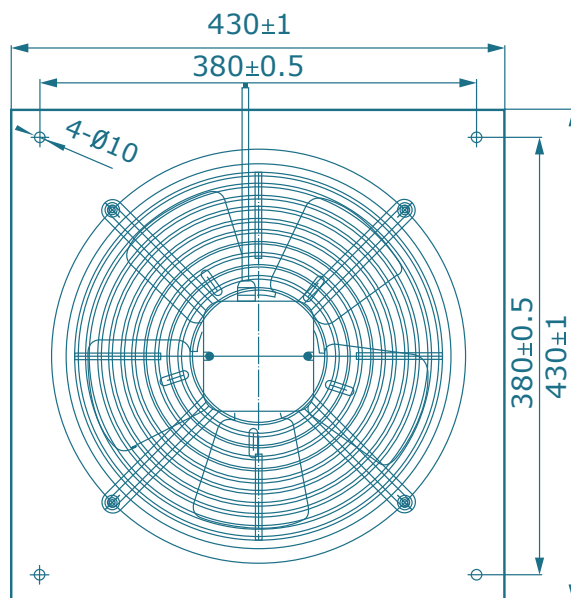

Airflow curves

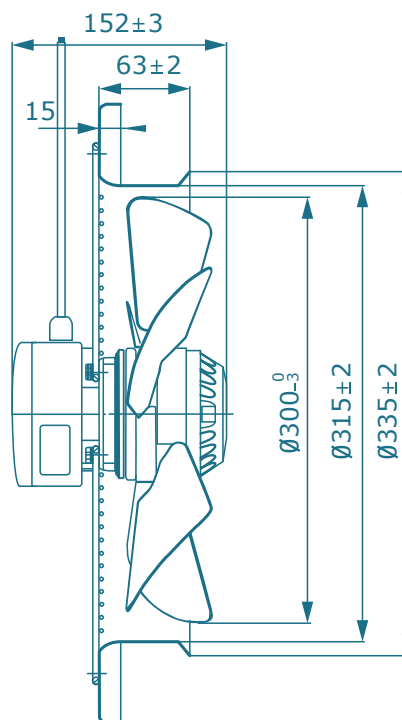
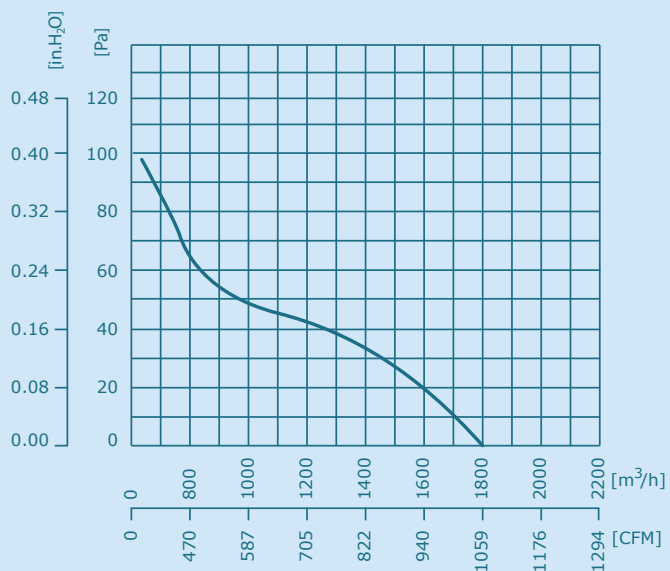

350 mm: TPF-4E-350A-5F

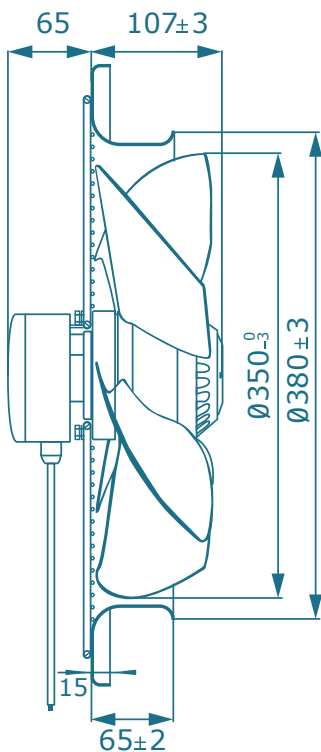
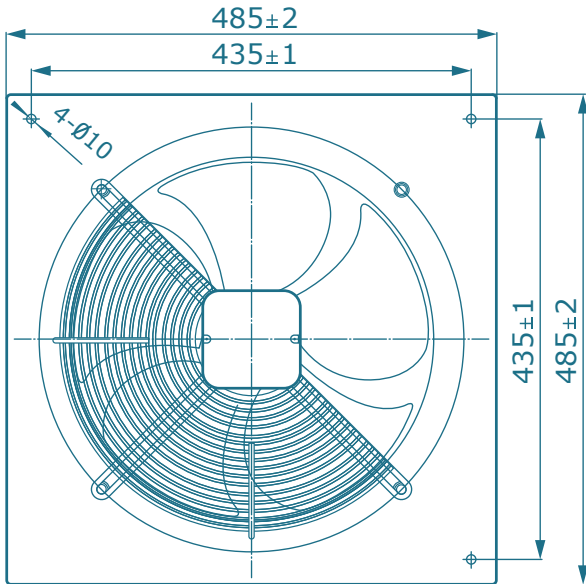

Diameter	350 mm
Power Supply	1~230 V, 50 Hz
Airflow @ 0 Pascal	2470 m ³ /hr
RPM	1350 min-1
Power Consumption	110 Watts
Current	0.48 Ampere
Capacitor	4 uF
Sound Pressure @ 1 Meter	58 dB (A)
Thermal Protection	F (155°C)
Protection Class	IP54
Net Weight	6.3 Kg

Airflow curves

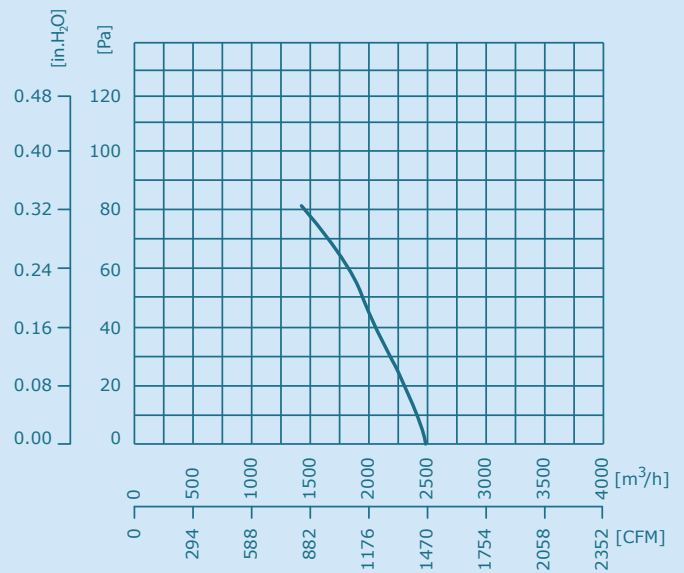

400 mm: TPF-4E-400A-5F

Diameter	400 mm
Power Supply	1~230 V, 50 Hz
Airflow @ 0 Pascal	3700 m ³ /hr
RPM	1350 min-1
Power Consumption	190 Watts
Current	0.90 Ampere
Capacitor	6 uF
Sound Pressure @ 1 Meter	60 dB (A)
Thermal Protection	F (155°C)
Protection Class	IP54
Net Weight	8 Kg

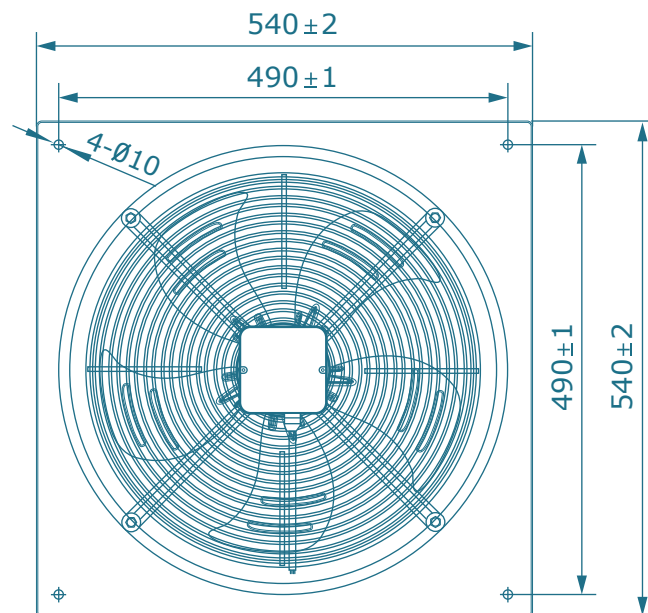

Airflow curves

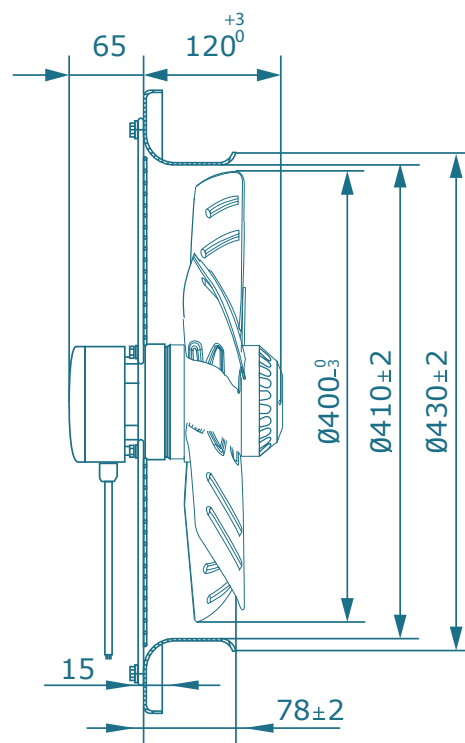
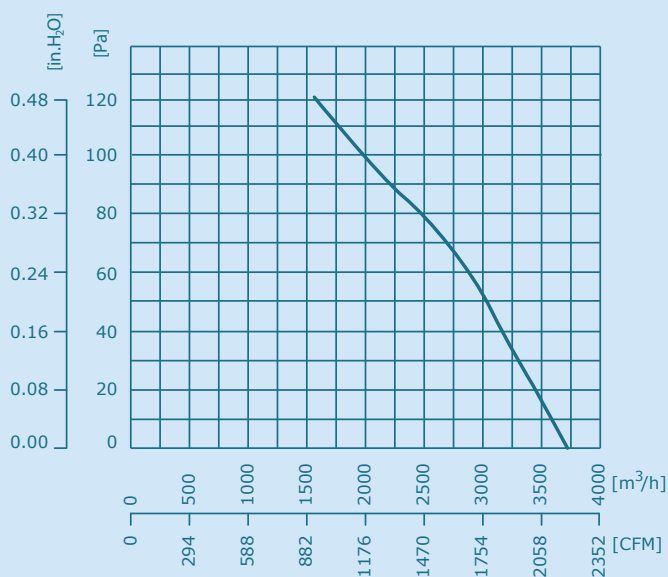

450 mm: TPF-4E-450A-5F

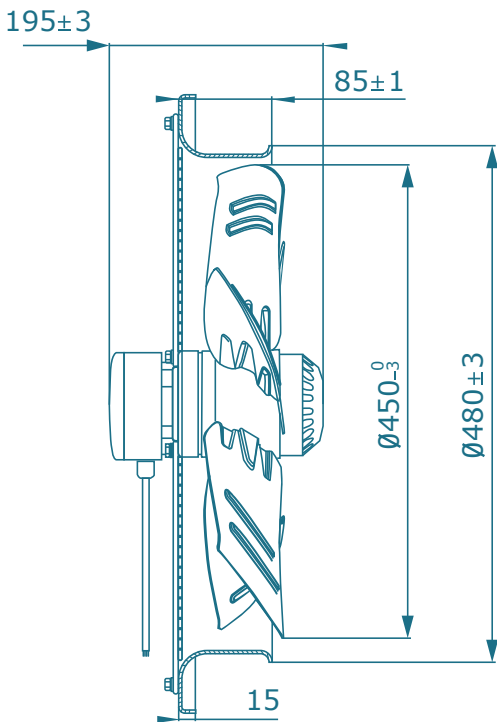
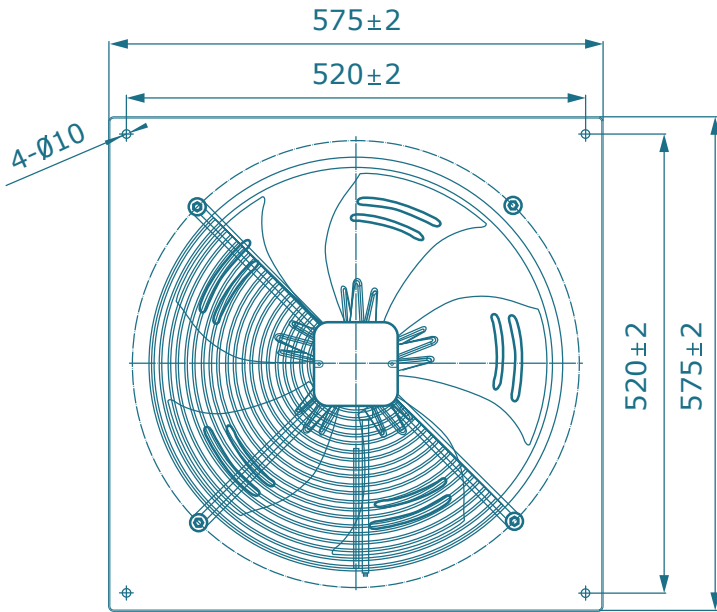

Diameter	450 mm
Power Supply	1~230 V, 50 Hz
Airflow @ 0 Pascal	5200 m ³ /hr
RPM	1350 min-1
Power Consumption	250 Watts
Current	1.15 Ampere
Capacitor	7 uF
Sound Pressure @ 1 Meter	68 dB (A)
Thermal Protection	F (155°C)
Protection Class	IP54
Net Weight	10 Kg

Airflow curves

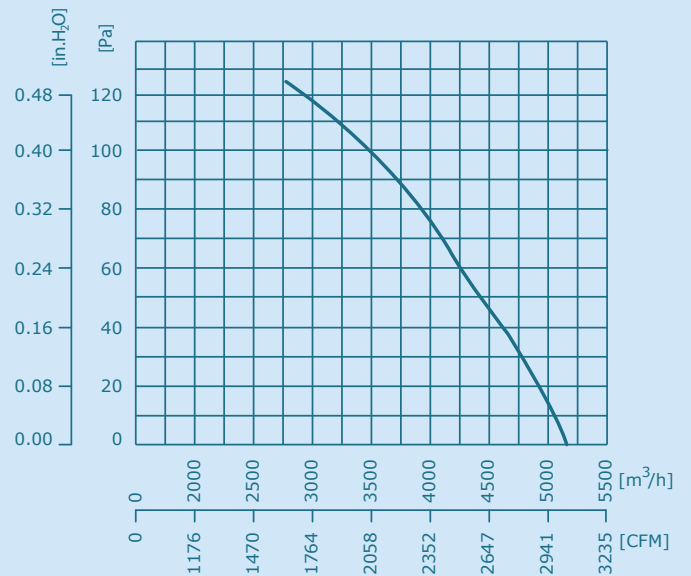

500 mm: TPF-4E-500A-5F

Diameter	500 mm
Power Supply	1~230 V, 50 Hz
Airflow @ 0 Pascal	7100 m ³ /hr
RPM	1320 min-1
Power Consumption	420 Watts
Current	2.0 Ampere
Capacitor	10 uF
Sound Pressure @ 1 Meter	69 dB (A)
Thermal Protection	F (155°C)
Protection Class	IP54
Net Weight	14 Kg

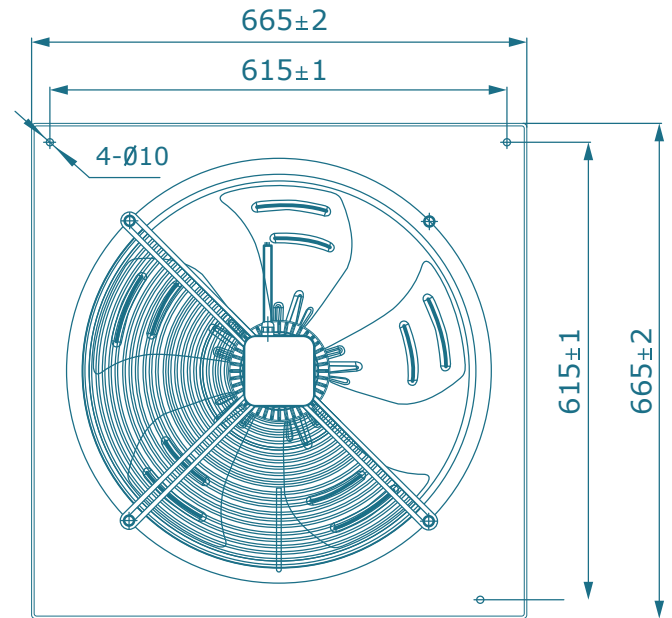

Airflow curves

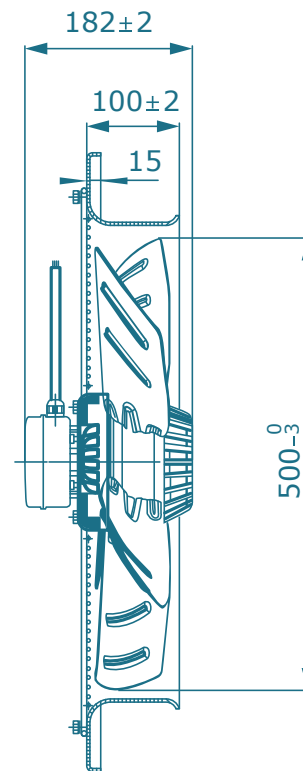
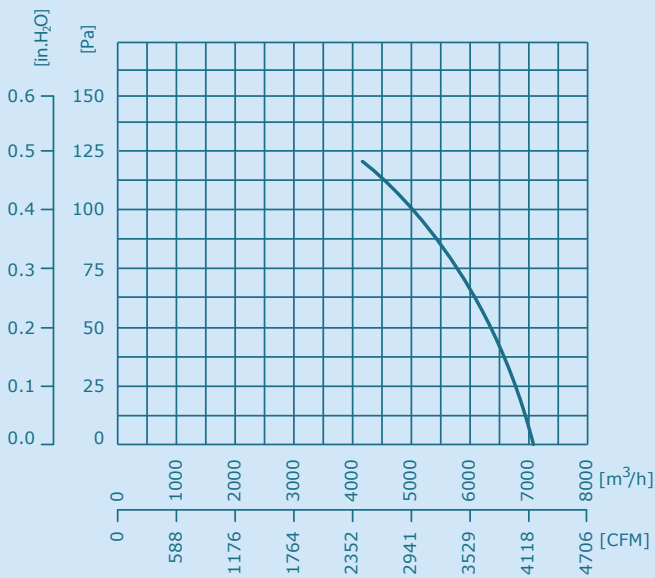

550 mm: TPF-4D-550A-5F

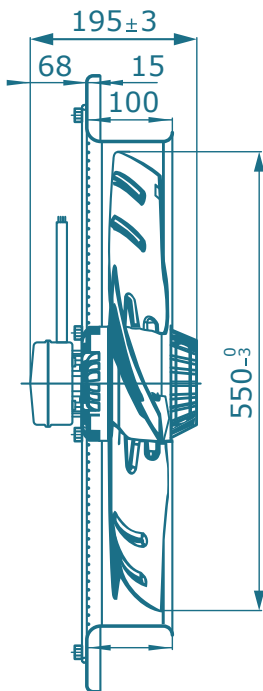
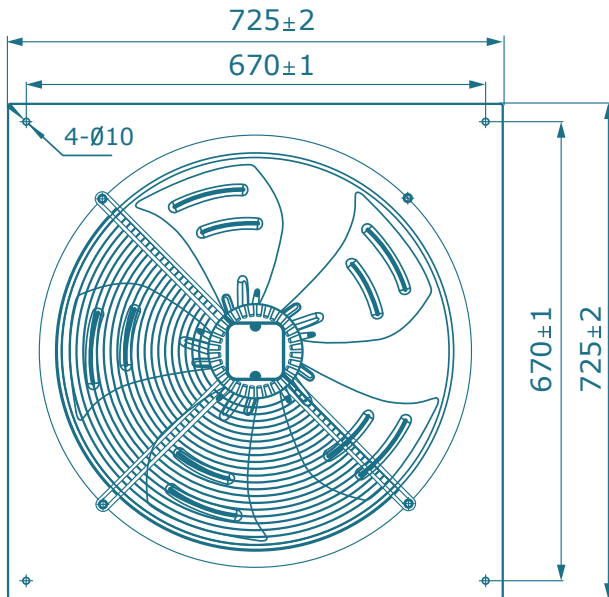

Diameter	550 mm
Power Supply	3~400 V, 50 Hz
Airflow @ 0 Pascal	8200 m ³ /hr
RPM	1330 min ⁻¹
Power Consumption	550 Watts
Current	1.1 Ampere
Sound Pressure @ 1 Meter	73 dB (A)
Thermal Protection	F (155°C)
Protection Class	IP54
Net Weight	18 Kg

Airflow curves

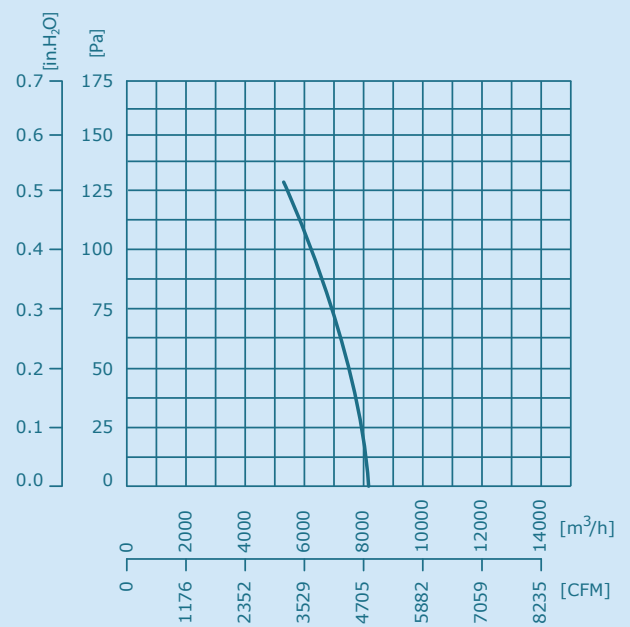

630 mm: TPF-4D-630A-5F

Diameter	630 mm
Power Supply	3~400 V, 50 Hz
Airflow @ 0 Pascal	11000 m ³ /hr
RPM	1350 min-1
Power Consumption	850 Watts
Current	1.6 Ampere
Sound Pressure @ 1 Meter	73 dB (A)
Thermal Protection	F (155°C)
Protection Class	IP54
Net Weight	22 Kg

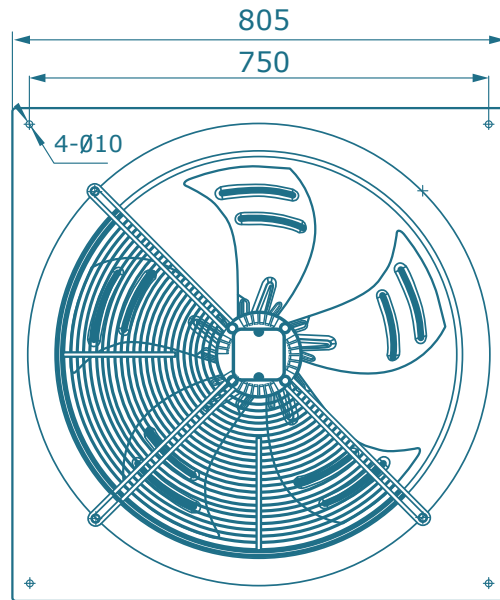

Airflow curves

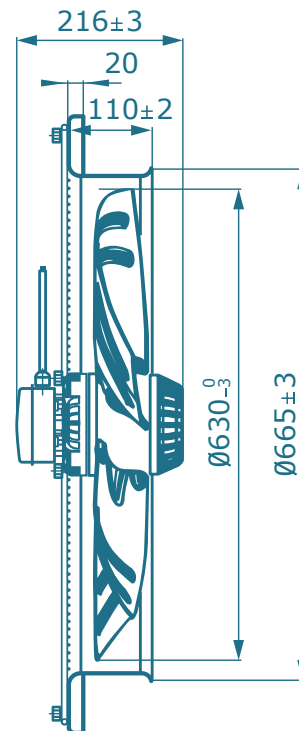
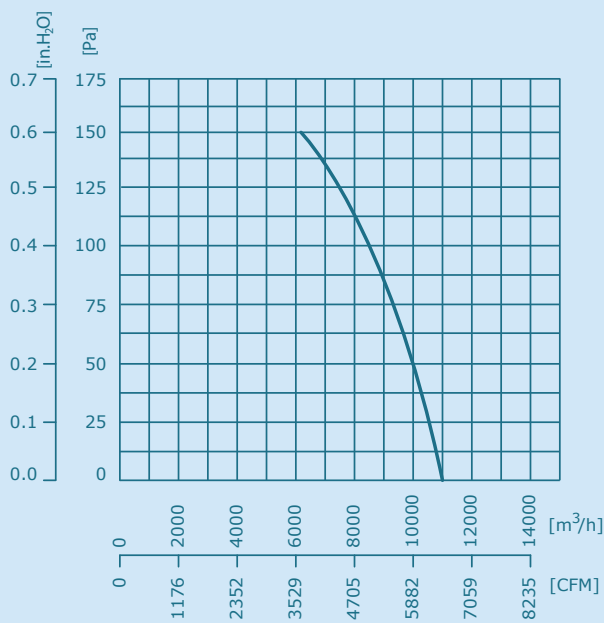

Nomenclature

TPF-2E-200A-5F

Propeller Fan Series

No of pole (2 Pole)
E- Single phase
D- Three Phase

Diameter - 200mm
Flow Direction
A-Blow type
V- Suction type

No of blade - 5
Grill mounting type -
G -Basket Grill only
F -Grill with mounting plate

Airflow Directions

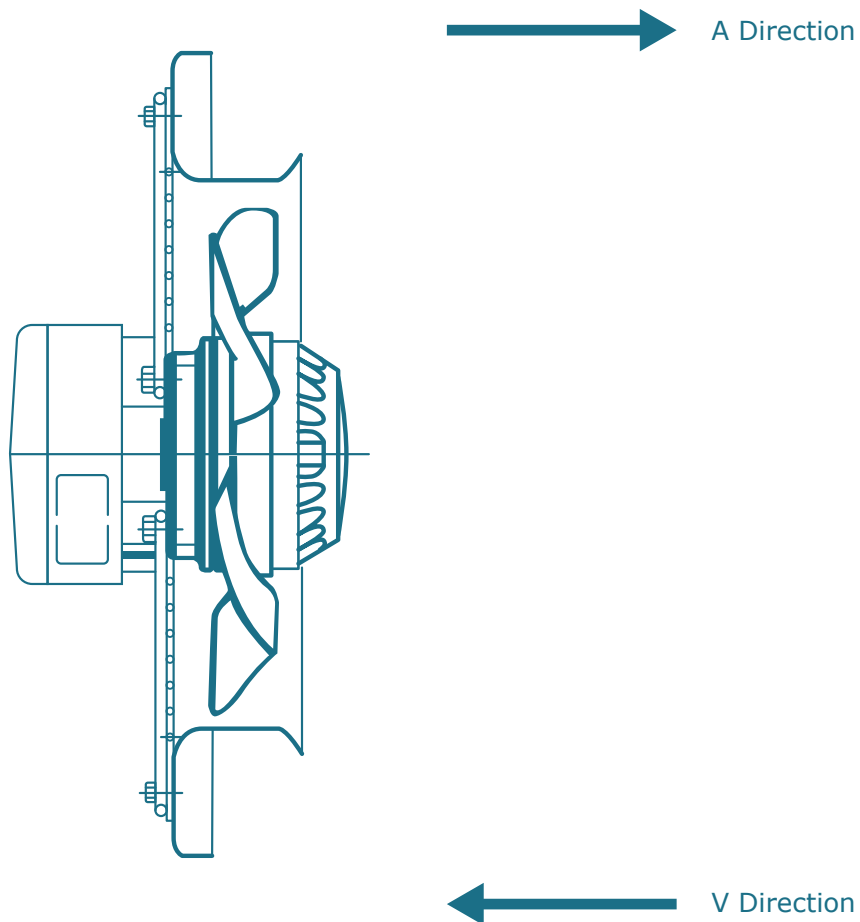

OEM PRODUCT RANGE



AXIAL FANS

High efficiency EC and AC motor
With Plastic and Metal blade



CENTRIFUGAL FANS

High efficiency EC and AC motor
Forward and Backward curved

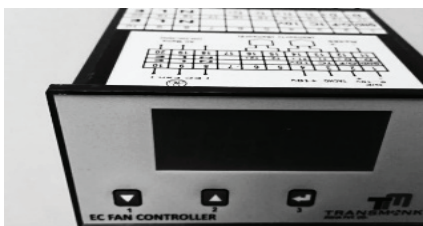

CONTROL SYSTEM

Temperature based 0-10V controller for EC fans.
Pressure based 0-10V controller for EC fans.
Temperature based control for AC axial and centrifugal Fans

Ventilation & HVAC Accessories



CIRCULAR INLINE FAN



PLASTIC DISC VALVE



CONSTANT AIRFLOW REGULATOR



COPPER JOINTS/REF NUTS

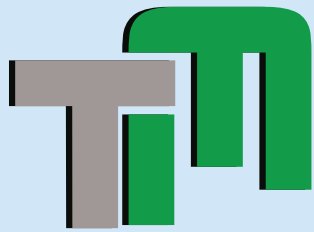

TRANSMONK

INDIA PVT. LTD.

The fan & HVAC Accessories Manufacturing

Office Address

Transmonk India Pvt. Ltd,
13, City Light CHSL, Plot No. 25, Sector 1,
Near Terna Polytechnic, Koparkhairane,
Navi Mumbai – 400709, Maharashtra

Warehouse Address

Transmonk India Pvt. Ltd,
Building No. F4, Unit No. 109, Bhumi
World, Mumbai Nashik Road Bhiwandi,
Thane, Mumbai - 421311, Maharashtra