



FanAir

**Normal Axial Fan Series-FAXF
Smoke Exhaust Axial Fan Series-FAXF-F**



www.fanair.in

Smoke Exhaust Tube Axial Flow Fan FAXF-F Series

- Direct Driven Type
- Size 315 to 1600 mm Diameter
- Air Performance Upto 221,000 CMH
- Static Pressure Upto 130 mmwg
- Adjustable / Controllable Pitch Impeller
- Fire Rated for **400 Deg C 30mins, 300 Deg C 2Hrs & 250 Deg C 2Hrs**
- Suitable for Basement Ventilation, Tunnel, Lift & Staircase Pressurization, Industrial Ventilation



Long Case Tube Axial Flow Fan FAXF Series



- Direct Driven Type
- Size 315 to 1600 mm Diameter
- Air Performance Upto 221,000 CMH
- Static Pressure Upto 130 MM WG
- Adjustable / Controllable Pitch Impeller
- Suitable for Basement Car Park, Tunnel, Lift & Staircase Pressurization, Industrial Ventilation

Short Case Tube Axial Flow Fan FAXF Series

- Direct Driven Type
- Size 315 to 1600 mm Diameter
- Air Performance Upto 221,000 CMH
- Static Pressure Upto 130 MM WG
- Adjustable / Controllable Pitch Impeller
- Suitable for Basement Car Park, Tunnel, Lift & Staircase Pressurization, Industrial Ventilation



QUICK SELECTIONS GUIDE

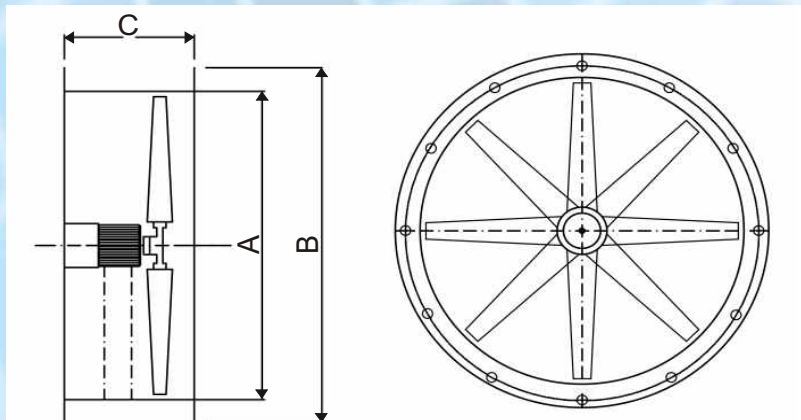
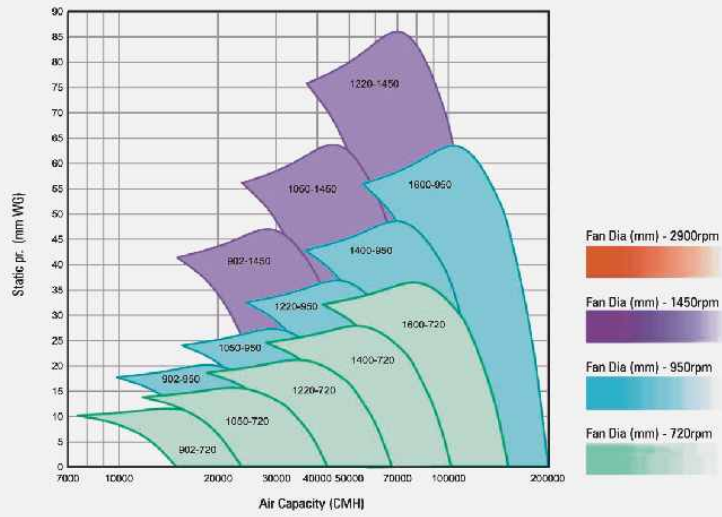
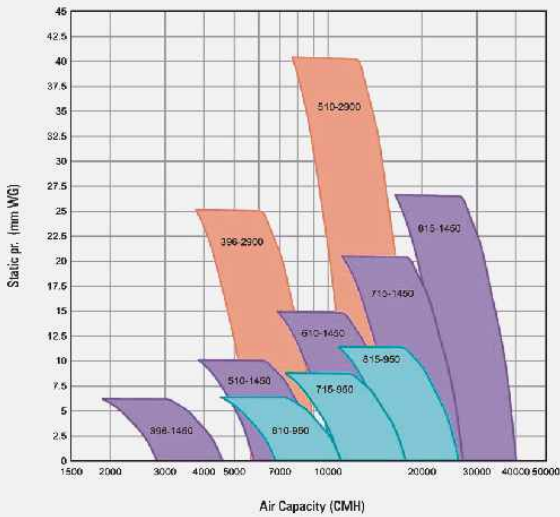

DIMENSION OF TUBE AXIAL FLOW FANS (all are in mm)			
Model	A	B	C
315	315	395	350
355	355	435	350
400	400	480	350
450	450	430	350
500	500	580	410
560	560	640	410
630	630	710	535
710	710	790	535
800	800	880	535
900	900	980	660
1000	1000	1080	660
1120	1120	1220	640
1250	1250	1350	700
1400	1400	1500	760
1600	1600	1700	800

Please follow fan performance curve for accurate selection

Jet Type Fan Series Series FAJF

- Direct Driven Type
- Sizes 315, 355 & 400 mm Diameter
- Air Performance Upto 11,000 CMH
- Dual Speed Fan
- Smoke Exhaust / Heat Ventilator
- Suitable for Basement Car Park Ventilation



Sound Attenuator

The Attenuator Casing are rolled with Galvanized steel sheet having ring end, tapped inserts for fixing and absorbent fiber glass insulation isolator with fiber glass tissue covering with perforated Al/GI Sheet
Size:- 315 mm Dia to 1600 mm Dia
Type :- Round & Rectangular Shape

